

Molecular mechanisms of higher MICs of antibiotics and quaternary ammonium compounds for *Escherichia coli* isolated from bacteraemia

Sylvie Buffet-Bataillon^{1,2*}, André Le Jeune², Sandrine Le Gall-David², Martine Bonnaure-Mallet²
and Anne Jolivet-Gougeon²

¹Unité d'Hygiène Hospitalière, Pôle Microorganismes, CHU Pontchaillou, Rennes, France; ²Equipe de Microbiologie, UPRES-EA 1254, Université de Rennes 1, Université Européenne de Bretagne, CHU Rennes, Rennes, France

*Corresponding author. EA 1254 Microbiologie, Unité d'Hygiène, Hôpital Pontchaillou, 2 rue Henri Le Guilloux, 35033 Rennes, France. Tel: +33-299284321; Fax: +33-299284365; E-mail: sylvie.buffet-bataillon@chu-rennes.fr

Received 14 December 2011; returned 9 February 2012; revised 27 June 2012; accepted 16 July 2012

Objectives: A previous study identified an association between high MICs of quaternary ammonium compounds (QACs) and antibiotic resistance. The current aim was to investigate the genetic background of this association.

Methods: Of 153 *Escherichia coli* clinical strains, seven were selected for their low or high MICs of antibiotics and/or QACs. Integron resistance gene contents were identified by sequencing after PCR amplification. The genes encoding the efflux pump AcrA/TolC and its regulatory regions *marA*, *marO*, *marR*, *soxS* and *rob* were sequenced. The gene expression of *acrA*, *tolC*, *marA*, *marOR*, *soxS* and *rob* was assessed by quantitative real-time PCR. MICs in the presence and absence of the efflux pump inhibitor phenyl-arginine- β -naphthylamide (PA β N) were compared.

Results: Of the seven strains, five were resistant to amoxicillin, amoxicillin/clavulanic acid and/or co-trimoxazole (trimethoprim/sulfamethoxazole) and/or had high MICs of ciprofloxacin and QACs. Four of the five harboured a class 1 integron (*intI1*). In three of these four strains, the presence of *dfrA/sul1* and *qacE Δ 1* gene cassettes correlated with resistance to co-trimoxazole and high MICs of QACs. In all of the five strains, overexpression of *tolC*, *marOR* and *soxS* was always associated with higher MICs of antibiotics and/or QACs. PA β N reduced the MICs of ciprofloxacin and QACs, suggesting that extrusion of ciprofloxacin and QACs from bacteria depends on the AcrAB–TolC system.

Conclusions: To our knowledge, this report is the first to describe dual involvement of the AcrAB–TolC system and class 1 integrons in clinical *E. coli* strains.

Keywords: biocides, *E. coli*, gene cassettes, gene expression

Introduction

The emergence of *Escherichia coli* isolates with multidrug-resistant (MDR) phenotypes, including co-resistance to four or more unrelated families of antibiotics and/or disinfectants, has been reported and is considered a serious health issue.¹ In recent years, there have been increasing concerns that quaternary ammonium compound (QAC) exposure may help drive selection of antibiotic-resistant bacteria. Antibiotic and QAC resistance genes, i.e. *qacE* or *qacE Δ 1*, are both carried on class 1 integrons. Class 1 integrons consist of a 5'-conserved segment (5'CS), variable regions containing the cassette genes and a 3'-conserved segment (3'CS).²

Alternatively, acquisition of an MDR phenotype in *E. coli* has also been linked to AcrAB overexpression.^{3–5} In *E. coli*, seven

homologous resistance–nodulation–cell division (RND)-type pumps are known. The tripartite AcrAB–TolC complex appears to be expressed constitutively at high levels and contributes significantly to the intrinsic resistance of *E. coli* to a number of antibiotics.⁶ The *mar* locus is known to encode the *marRAB* operon, specifying the repressors MarR and MarA, SoxS and Rob, which positively regulate the operon and affect AcrAB expression.⁷ Pharmacological inhibition of MDR efflux pumps might be an attractive goal for reversing drug resistance in *E. coli* species and to improve therapy options. Phenyl-arginine- β -naphthylamide (PA β N) has been reported to be a broad-spectrum efflux pump inhibitor (EPI) capable of reversing the MDR phenotype of Gram-negative bacteria.⁸

In a previous study,⁹ we demonstrated an epidemiological relationship between high MIC values of QACs and antibiotic

resistance in 153 clinical *E. coli* isolates. In multivariate analysis, antibiotic susceptibility to co-trimoxazole (trimethoprim/sulfamethoxazole) was independently associated with the alkyl dimethyl benzyl ammonium chloride (ADBAC) MIC (≤ 16 mg/L) and the dodecyl dimethyl ammonium chloride (DDAC) MIC (≤ 8 mg/L), and antibiotic susceptibility to co-trimoxazole was also associated with susceptibility to amoxicillin and to nalidixic acid ($P < 0.05$).

The aim of the present study was to investigate in seven clinical isolates selected for their low or high MICs of antibiotics and/or QACs⁹ (plus two reference *E. coli* strains) (i) the expression and occurrence of structural changes in genes encoding the AcrA/TolC efflux pump and its regulatory proteins MarA, MarOR, SoxS and Rob and (ii) the presence of integrons and their gene cassette content. We also used a phenotypic approach (comparison of MICs in the presence and absence of PA β N) to determine the exact nature of the resistance mechanism and connect the susceptibility and genetic results already obtained.

Materials and methods

Bacterial strains, antibiotic susceptibility testing and MICs of QACs in the presence or absence of PA β N

Out of 153 *E. coli* isolates,⁹ seven clinical isolates were selected for their low (strains 3 and 4) or high (strains 5–9) MICs of amoxicillin, co-trimoxazole and/or QACs (see Table 2). Broth and agar were obtained from AES (AES Laboratory, Combours, France) and ADBAC and DDAC from Laboratoire Anios (France). *E. coli* ATCC 14536 (strain 1) and *E. coli* K12DH10B (strain 2) were used as test strains for MIC determination, in RT-PCR for relative quantification of expression and for DNA sequencing. *E. coli* harbouring *intI1*, *intI2* and *intI3* were kindly provided by T. M. Coque and colleagues. Susceptibilities to a panel of different antibiotics were studied by the Etest method (bioMérieux, France) on Mueller–Hinton agar in the presence or absence of PA β N⁸ (100 mg/L; Sigma, France), in accordance with the CLSI and the recommendations of the European Committee on Antibiotic Susceptibility Testing (EUCAST-2011; http://www.euca.org/clinical_breakpoints/). In the absence of recommendations for breakpoints for streptomycin for Enterobacteriaceae, given in EUCAST-2011, the streptomycin epidemiological cut-off value for *E. coli* was determined as previously recommended (≤ 8 mg/L).^{10,11} The antibiotics tested included amoxicillin, amoxicillin/clavulanic acid, imipenem, cefotaxime, streptomycin, spectinomycin, amikacin, ciprofloxacin and co-trimoxazole. As previously described,⁹ microdilution tests were performed in Mueller–Hinton agar to determine the MIC of ADBAC or DDAC. A 4-fold or greater reduction in MIC values after the addition of PA β N was considered significant.⁸

DNA, PCR and sequencing

DNA was extracted using the DNAeasy kit (Qiagen, Courtaboeuf, France). Different PCR mapping experiments were performed using the primer sets described in Table 1. All PCRs were performed using 5 \times first-strand reaction buffer, 10 mM of each deoxynucleoside triphosphate, 10 μ M of each primer in the set and 2 units/ μ L of *Taq* DNA polymerase (Finnzymes, Saint Quentin, France). The first amplification programme to search for the presence of mutations that might affect *acrA* or *tolC* and the regulatory genes *marA*, *marOR*, *soxS* or *rob* was 45 s at 98°C and 30 cycles of 10 s at 98°C, 30 s at 60°C and 45 s at 72°C, with a final extension step of 10 min at 72°C. The amino acid sequences of AcrA, TolC, MarA, MarO, MarR, SoxS and Rob encoded by eight *E. coli* strains (strains 1

Table 1. Primers used in this study

Gene amplified	Oligonucleotide sequence pairs (5' to 3')
DNA sequencing of the AcrAB–TolC efflux pump and its regulators	
<i>acrA</i>	CGACGATAATATAAACGCGACGA and TTATCATCATGTTGGCAGGG
<i>tolC</i>	CACGTAACGCCAACCTTTTG and TTCTCGCTTCAATTCGACCA
<i>marA</i>	CGGACGAAGTGGCAACAC and TTATCTCTTTCCGCGCAG
<i>marOR</i>	TCAGCGAAAAGTATAAGGGGTAA and GACTGGATCGAGGACAACCT
<i>soxS</i>	TTCCATAAATCGTTTACCTCA and AAAGAACCATCCCTGGCAAT
<i>rob</i>	CACTGAATGCTAAAACAGCAAAA and GCTTTCCTGATAATCCACGC
Gene expression of the AcrAB–TolC efflux pump and its regulators by real-time RT–PCR	
<i>q-acrA</i>	TTGACATCCACGGAAGTTTT and TGGCAGTCTCCTTTGAGTTC
<i>q-tolC</i>	TACGCGTACCATTGTTGATG and CAACGTACCAGAGCTGACT
<i>q-marA</i>	CCATTCATAGCATTTTGGACT and GCTCGTTACTTTCTTCAGC
<i>q-marOR</i>	CTTTAGTAGCCTTGCATCG and TAAGCGACCCAATGGAATAA
<i>q-soxS</i>	TGAACACTGAAAAGAGGCGAGA and GCGTTGGCGAATGTAATC
<i>q-rob</i>	CAGTCTGGCAGCATTTTCT and TAAGCGACCCAATGGAATAA
<i>q-ARN16S</i>	TTGACATCCACGGAAGTTTT and TGGCAGTCTCCTTTGAGTTC
PCR detection of class 1, 2 and 3 integrase genes	
<i>intI1</i>	GGTCAAGGATCTGGATTTTCG and ACATGCGTGTAAATCATCGTC
<i>intI2</i>	CACGGATATGCGACAAAAGGT and GTAGCAAACGAGTGACGAAATG
<i>intI3</i>	AGTGGGTGGCGAATGAGTG and TGTTCTTGATCGGCAGGTG
PCR detection of associated gene cassette regions and of Pc-P2 promoter sequences	
<i>int1-sull</i>	CGAAATCCAGATCCTTGACC and GTGGGGCTTTGTAGGTATGG
5'CS–3'CS	CGCATCCAAGCAGCAAG and TCAGGTCAAGTCTGCTT
<i>aadA1</i>	ACAATTCGTTCAAGCCGACG and CGTCGGCTTGAACGAATTGT
<i>aadA5</i>	TAACCTGGCGTTCAAGCCGGA and TCCGCTTGAACGCCGAGTTA
<i>qacEΔ1</i>	CTTCGCGCTTGTACATAATC and AACCAGGCAATGGCTGTAAT

and 3–9) were compared with *E. coli* K12DH10B (strain 2). The second amplification programme to detect *intI1*-, *intI2*- or *intI3*-positive samples was 45 s at 98°C and 30 cycles of 10 s at 98°C, 30 s at 61°C (*intI1*) or 64°C (*intI2* and *intI3*) and 45 s at 72°C, with a final extension step of 10 min at 72°C. The third amplification programme to search for associated gene cassette regions and Pc-P2 promoter sequences was 45 s at 98°C and 30 cycles of 10 s at 98°C, 30 s at 59°C and 45 s at 72°C, with a final extension step of 10 min at 72°C. Amplified products underwent bidirectional sequencing using the BigDye terminator (Applied Biosystems, Courtaboeuf, France). The PCR programme for all sequencing reactions included 25 cycles of 10 s at 96°C, 5 s at 50°C and 45 min at

60°C. Among class 1 integrons, we analysed the Pc-P2 combinations defined on the basis of their -35 and -10 hexamer sequences and their spacing (14 or 17 bp) between potential -35 and -10 hexamer sequences.¹²

RNA and RT-PCR

An overnight culture was diluted 1:100 in Mueller-Hinton broth and grown to the late log phase of growth (2 h at 37°C). RNA was extracted and treated with DNase using the RNeasy kit (Qiagen). Contaminating genomic DNA was digested by DNase (RNase-Free DNase Set, Qiagen) for 30 min at 30°C. RNA yield and quality were measured using the Nano-drop 2000 spectrophotometer (Thermo Scientific, Courtaboeuf, France) and Bioanalyzer 2100 (Agilent, Garches, France). cDNAs were synthesized from 0.5 µg of RNA template using the Quantitect Reverse Transcription Kit according to the manufacturer's instructions (Qiagen). Table 1 gives the primers used. RT-PCR conditions were 2 min at 25°C and 90 min at 42°C. Relative quantification of *acrA*, *tolC*, *marA*, *marOR*, *soxS* and *rob* was performed using StepOnePlus (Applied Biosystems) with the SYBR Green PCR Master Mix (Applied Biosystems). Fold-change values were calculated after normalization of each gene to the 16S rRNA internal control, using the comparative threshold method with *E. coli* ATCC 14536 (strain 1) as the reference strain.¹³ Each sample was run in triplicate. Changes in gene expression were considered relevant only if there was at least a 2-fold change compared with the reference strain, and significant if a *t*-test had a *P* value ≤0.05, as described previously.¹⁴

Bioinformatics tools

Multiple sequences were aligned using Clustal W (<http://www.ebi.ac.uk/clustalw/index.html>).

Sequences were compared with *E. coli* K12DH10B (strain 2). To search for associated gene cassette regions, homology searches were carried out using BLAST (<http://www.ncbi.nlm.nih.gov/>) and GENEIOUS (<http://www.geneious.com>).

Results

Antimicrobial susceptibility

Cross-resistance among amoxicillin, amoxicillin/clavulanic acid and co-trimoxazole and high-level MICs of QACs were observed for strains 5, 6 and 7. Strain 8 was resistant to amoxicillin, amoxicillin/clavulanic acid, co-trimoxazole and ciprofloxacin and had low-level MICs of QACs, in contrast to strain 9, which was antibiotic susceptible and had high-level MICs of QACs. Resistance to spectinomycin was observed only for strain 8. Resistance to streptomycin was observed for strains 2, 6, 7 and 8. Strains 5, 6 and 8 were resistant to fluoroquinolones (Table 2). PAβN at a concentration of 100 mg/L had various effects on the MICs of the test drugs (Table 2), reducing the MICs of ciprofloxacin by 2-fold or more in strains 5, 6 and 8. Particularly strong effects with PAβN at 100 mg/L were observed with ADBAC and DDAC. In contrast, PAβN was unable to reduce the MIC of amoxicillin, amoxicillin/clavulanic acid, spectinomycin, streptomycin or co-trimoxazole (Table 2).

Integrons

The four amoxicillin- and co-trimoxazole-resistant strains (5–8) harboured class 1 integrons containing different cassettes. Class 1 integrons were found with identity to genes encoding

Table 2. Comparison of MIC values and changes in gene expression between *E. coli* strains and *E. coli* ATCC 14536 (strain 1)

<i>E. coli</i> strain ^a	MIC (mg/L) ^b										Fold change in gene expression (based on group means) ^c						
	AMX	AMC	CTX	IPM	SPT	STR	AMK	SXT	CIP	ADBAC	DDAC	acrA	tolC	marA	marOR	soxS	rob
1	3	2	0.023	0.125	6	3	1.5	0.064	0.008	4 ^f	4 ^f	1.03±0.01	0.88±0.05	0.63±0.07	0.97±0.13	0.65±0.08	1.13±0.15
2	3	3	0.032	0.19	9	<	1.5	0.047	0.002	4 ^f	4 ^f	1.10±0.02	1.09±0.09	0.64±0.17	0.62±0.03	0.71±0.06	0.89±0.09
3	3	3	0.032	0.125	16	3	1.5	0.094	0.012	4 ^f	4 ^f	0.89±0.08	0.66±0.04	0.38±0.15	0.65±0.01	0.82±0.01	0.86±0.18
4	3	3	0.047	0.125	8	6	4	0.094	0.008	8 ^f	8 ^f	0.91±0.07	2.31±0.10	12.87±1.73	3.73±0.76	303.62±71.56	4.52±0.97
5	>256	9	0.125	0.125	16	8	2	>32	3 ^d	64 ^g	16 ^g	1.06±0.06	4.87±0.72	3.38±0.29	3.59±0.94	12.80±2.52	1.87±0.21
6	>256	9	0.094	0.125	12	>1024	2	>32	1.5 ^e	64 ^g	16 ^g	0.99±0.01	2.75±0.52	1.73±0.02	18.76±0.24	88.38±10.04	2.05±0.45
7	>256	9	0.064	0.125	32	>768	1.5	>32	0.016	64 ^g	16 ^g	1.01±0.02	4.53±2.42	3.23±1.05	4.61±0.87	5.65±1.85	2.75±0.21
8	>256	16	1	0.19	128	16	1	>32	32 ^f	8 ^f	2 ^e	0.94±0.04	3.66±0.30	6.85±1.90	2.87±0.59	1.10±0.10	6.26±0.47
9	3	3	0.047	0.19	21	4	2	0.094	0.016	32 ^f	16 ^f						

^aStrains containing class 1 integrons are underlined.

^bAMX, amoxicillin; AMC, amoxicillin/clavulanic acid; CTX, cefotaxime; IPM, imipenem; SPT, spectinomycin; STR, streptomycin; AMK, amikacin; SXT, trimethoprim/sulfamethoxazole; CIP, ciprofloxacin. Values corresponding to resistance and increased MICs of ADBAC and DDAC (>16 and >8 mg/L) are in bold.

^cBold indicates at least a 2-fold change in gene expression compared with isolate 1, *E. coli* ATCC 14442.

^dReduction of the MIC by 2-fold in the presence of PAβN.

^eReduction of the MIC by 4-fold in the presence of PAβN.

^fReduction of the MIC by 8-fold in the presence of PAβN.

^gReduction of the MIC by >8-fold in the presence of PAβN.

site-specific integrase (*intI1*), dihydrofolate reductase A (*dfrA*, trimethoprim resistance), aminoglycoside adenylyltransferase A (*aadA*, streptomycin/spectinomycin resistance), deleted derivative QACs (*qacEΔ1*, low-level resistance to antiseptics and disinfectants) and sulphonamides (*sul1*, sulphonamide resistance). Strains 5 and 8 contained an arrangement consisting of a module *dfrA1-aadA1-qacEΔ1-sul1*; strain 7 an arrangement of *dfrA17-aadA5-qacEΔ1-sul1*; and strain 6 a truncated *intI1* gene cassette (Figure 1). Table 2 and Figure 1 show the associations among antibiotic resistance, QAC MICs and detection of class 1 integrons. The presence of cassettes coding for high MICs of antimicrobial agents was demonstrated among strains 5, 7 and 8 for co-trimoxazole (*dfrA/sul1*) and among strains 5 and 7 for QACs (*qacEΔ1*). Although strains 5, 7 and 8 contained a class 1 integron that harboured a streptomycin/spectinomycin resistance gene (*aadA*), only strain 8 was resistant to streptomycin/spectinomycin and strain 7 to streptomycin. In class 1 integrons, promoter Pc combined with promoter P2 drove the expression of cassette genes. Strains 5, 7 and 8 contained a Pc weak –35 TGGACA and –10 TAAGCT spaced from 17 bp and an inactive P2 promoter –35 TTGTTA and –10 TACAGT spaced from 14 bp.

Class 2 or 3 integrons were not detected in any of the strains studied. Strains susceptible to co-trimoxazole, amoxicillin, amoxicillin/clavulanic acid, cefotaxime, imipenem, amikacin and ciprofloxacin did not carry class 1 integrons. Despite the fact that the MICs of QACs were high in strain 9, this strain did not carry any class 1 integron and thus no *qacEΔ1* gene cassette.

Efflux pumps

Resistance to antibiotics and high MICs of QACs may be based on an active export mechanism by efflux pumps. The expression and the integrity of coding sequences of the pumps, like those of their regulators and promoters, were assayed. Known regulators of the AcrAB-TolC efflux pump include the regulatory genes *marA*, *marO*, *marR*, *soxS* and *rob*.^{3,15,16}

Sequencing of these genes was first performed to detect some mutations potentially responsible for variations in gene expression. Table 3 shows the amino acid sequences of AcrA, TolC, MarA, MarO, MarR, SoxS and Rob. The same mutation A→T was located in the amino acid sequence of TolC in strains 3, 5, 7 and 8 and did not increase the *tolC* expression in comparison with strain 1 (Tables 2 and 3). A similar observation was made for the point mutation T→A detected in the amino acid sequence of AcrA. The same mutations (G→S; Y→H) were detected in the sequence of MarR in all strains except strain 2. Another mutation point, S→N, in the sequence of MarR was located in strains 5 and 7, but did not increase the *marOR* expression in comparison with strain 1 (Tables 2 and 3). No amino acid mutations in MarO or SoxS were detected, and a single mutation L→Q located in the sequence of MarA in strain 7 was identified. No changes in nucleotide positions within *marO* sites I and II and ‘marbox’ were detected. The same mutation A→C in the ‘accessory marbox region’ within *marO* was located in 1332 for eight strains (1 and 3–9). None of the mutations detected in the amino acid sequences of AcrA, TolC, MarA, MarO, MarR, Rob and SoxS could explain fluctuations in *marRAB* gene expression (Table 2).

The next step was RT-PCR to analyse expression of genes coding the pump AcrAB/TolC and its main regulators. None of the susceptible strains overexpressed any genes. Expression of *acrA* remained constant for all tested strains whether or not they were resistant to antibiotics and/or the level of MICs of QACs. Indeed, the five clinically resistant strains (strains 5–9) always overexpressed *tolC* and *marOR* genes (Table 2). Overexpression of *tolC* correlated with resistance to amoxicillin, amoxicillin/clavulanic acid and co-trimoxazole and/or high-level MICs of QACs. In strain 9, which was susceptible to antibiotics, higher MICs of QACs were related to overexpression of *tolC*, *marA*, *marOR* and *rob*.

Discussion

Most studies demonstrating a relationship between resistance to antibiotics and disinfectants have been performed on laboratory

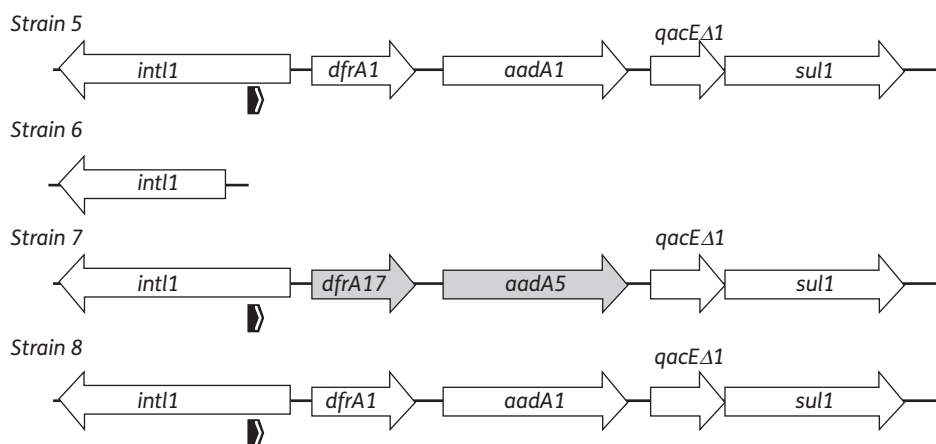

Figure 1. PCR map of the integron structure in the *E. coli* strains 5–8. Represented genes are: *intI1*, site-specific integrase; *dfrA*, trimethoprim-resistant dihydrofolate reductase; *aadA*, streptomycin and spectinomycin resistance gene; *qacEΔ1*, deleted derivative *qacE* associated with low-level resistance to antiseptics and disinfectants; and *sul1*, sulphonamide resistance gene. In the 5'CS of integrons, the promoter Pc (black arrow) consists of a –35 region TGGACA separated by 17 bases from a –10 region TAAGCT and the secondary promoter P2 (white chevron) consists of a –35 region TTGTTA separated by 14 bases from a –10 region TACAGT.

Table 3. Characteristics of mutations in AcrA, TolC, MarA, MarO, MarR, SoxS and Rob compared with *E. coli* K12DH10B (strain 2)

<i>E. coli</i> strain	Amino acid mutation						
	AcrA	TolC	MarA	MarO	MarR	SoxS	Rob
1	19; S→R 26; D→G 69; R→C	—	—	—	103; G→S 137; Y→H	—	—
3	104; T→A	233; A→T	—	—	103; G→S 137; Y→H	—	156; R→H
4	—	—	—	—	103; G→S 137; Y→H	—	—
5	104; T→A	233; A→T	—	—	3; S→N 103; G→S 137; Y→H	—	20; Q→H 171; A→S
6	104; T→A	332; V→F	—	—	103; G→S 137; Y→H	—	—
7	104; T→A	233; A→T 490; P→S	70; L→Q	—	3; S→N 103; G→S 137; Y→H	—	20; Q→H 171; A→S
8	104; T→A	233; A→T	—	—	103; G→S 137; Y→H	—	—
9	—	—	—	—	103; G→S 137; Y→H	—	—

strains or mutants, often in the presence of antibiotics or disinfectants.¹⁷ Here the mechanism of resistance to antibiotics and of high MICs of QACs was studied in *E. coli* clinical isolates without exposing them *in vitro* to increasing antibiotic or QAC concentrations.

Integrations

Class 1 integrons were characterized by two conserved segments, 5'CS and 3'CS, that flank the variable gene cassette region. The 5'CS region containing the potential promoter Pc allows expression of the inserted cassette genes. Pc-P2 combinations were Pc weak and P2 inactive. The weaker the promoter is, the stronger the integrase.¹² The variable region consisted of *dfrA* and *aadA* gene cassettes affecting trimethoprim (*dfrA*), streptomycin and spectinomycin (*aadA*). The 3'CS of class 1 integrons contained *qacEΔ1* and *sul1*, which mediate low-level resistance to QACs (*qacEΔ1* encodes an efflux pump belonging to the small multidrug resistance family) and to sulfamethoxazole (*sul1*).¹⁸

In this study, the presence of *dfrA/sul1* and *qacEΔ1* gene cassettes was linked, respectively, to resistance to co-trimoxazole and high MICs of QACs for three of four integron-positive strains. This result was not unexpected. We have previously reported that high MICs of QACs for clinical *E. coli* were associated with antibiotic resistance to co-trimoxazole and strongly associated with susceptibility to amoxicillin and nalidixic acid ($P < 0.01$).⁹ Among strains 5, 6, 7 and 8, resistant to amoxicillin, and 5, 6 and 8, resistant to ciprofloxacin, none harboured genes encoding resistance to β -lactams (*bla*_{TEM}, *bla*_{SHV-1}, *bla*_{OXA-1} and *bla*_{PSE-1}) or to fluoroquinolones (*qnrA*) within the class 1 integron.^{19,20} The presence of the *aadA* gene cassette was related

to high MICs of spectinomycin for strains 5, 7 and 8. Several resistance mechanisms have been demonstrated for isolates harbouring high streptomycin MICs.¹¹

Efflux pumps

The overexpression of *tolC* in strains with high MICs of antibiotics and/or QACs was unsurprising given previous evidence showing that strains deleted for *tolC* exhibit hypersusceptibility to various antibiotics and ADBAC.⁶ As a consequence, TolC is considered a major element of the efflux pump system directly involved in antimicrobial multiresistance.²¹ Transcriptional activators such as MarA, SoxS and MarR have been shown to regulate the expression of the AcrAB–TolC efflux pump. Overexpression of *tolC*, *marA*, *marOR*, *soxS* and *rob* was observed in strains with high MICs of antibiotics and/or QACs. Our report did not find any mutation or deletion in the MarA or MarR binding sites previously described in the increase of MICs of antibiotics and/or QACs.¹⁶

At 100 mg/L, PA β N reduced the MIC of ciprofloxacin and QACs, but remained ineffective in reducing the MIC of amoxicillin, amoxicillin/clavulanic acid, spectinomycin, streptomycin and co-trimoxazole. PA β N had effects on fluoroquinolone MICs for *E. coli*, a finding consistent with a report by Kern *et al.*⁸ The poor activity of PA β N on β -lactam and aminoglycoside MICs for strains has also been reported by Kern *et al.*⁸ However, the ability of PA β N to reduce the MICs of the two QACs, ADBAC and DDAC, is remarkable and has not previously been reported. Moreover, PA β N, as a known competitive inhibitor of RND efflux pumps, could explain the association between high MICs of fluoroquinolones and QACs and overexpression of *tolC* and its regulators.²² In a study by O'Regan *et al.*,²³ both *soxS* and *marA* were overexpressed in an *in vitro*-derived ciprofloxacin-resistant mutant.

In conclusion, the findings of the present study demonstrate different resistance mechanisms connected to the susceptibility tests and genetic investigation. High MICs of ciprofloxacin and QACs were related to overexpression of *tolC* and its regulators, a finding demonstrated by the capacity of the EPI PA β N to reduce the MICs of ciprofloxacin and QACs. The same efflux pumps can be used in the presence of various antimicrobial agents, and their expression can induce extrusion of several different molecules and then participation in MDR mechanisms. As a result, development of a means to circumvent or block specific efflux mechanisms could lead to important innovations in treating infectious disease agents. The *dfrA/sul1* and *qacE Δ 1* gene cassettes within the class 1 integron were associated with high MICs of QACs and of co-trimoxazole, indicating that we should be aware that the integration of gene cassettes conferring resistance to antimicrobial agents in integrons is likely to be only a matter of time. These results emphasize the need to promote new biocide regulation.

Acknowledgements

We gratefully thank Anne Marie Gouraud and Philippe Gautier for technical assistance, Céline Allaire for editorial assistance and T. M. Coque and colleagues (Servicio de Microbiología, Hospital Universitario Ramón y Cajal, Madrid, Spain) for kindly providing *E. coli* harbouring *int11*, *int12* and *int13*.

Funding

This study was supported by Fondation Langlois, Conseil Régional de Bretagne and Funds Feder (Europe).

Transparency declarations

None to declare.

References

- 1 Maynard C, Fairbrother JM, Bekal S et al. Antimicrobial resistance genes in enterotoxigenic *Escherichia coli* O149:K91 isolates obtained over a 23-year period from pigs. *Antimicrob Agents Chemother* 2003; **47**: 3214–21.
- 2 Ploy MC, Lambert T, Couty JP et al. Integrons: an antibiotic resistance gene capture and expression system. *Clin Chem Lab Med* 2000; **38**: 483–7.
- 3 Fralick JA. Evidence that TolC is required for functioning of the Mar/AcrAB efflux pump of *Escherichia coli*. *J Bacteriol* 1996; **178**: 5803–5.
- 4 Alekshun MN, Levy SB. Regulation of chromosomally mediated multiple antibiotic resistance: the *mar* regulon. *Antimicrob Agents Chemother* 1997; **41**: 2067–75.
- 5 Nishino K, Nikaido E, Yamaguchi A. Regulation and physiological function of multidrug efflux pumps in *Escherichia coli* and *Salmonella*. *Biochim Biophys Acta* 2009; **1794**: 834–43.
- 6 Sulavik MC, Houseweart C, Cramer C et al. Antibiotic susceptibility profiles of *Escherichia coli* strains lacking multidrug efflux pump genes. *Antimicrob Agents Chemother* 2001; **45**: 1126–36.
- 7 Schneiders T, Barbosa TM, McMurry LM et al. The *Escherichia coli* transcriptional regulator MarA directly represses transcription of *purA* and *hdeA*. *J Biol Chem* 2004; **279**: 9037–42.
- 8 Kern WV, Steinke P, Schumacher A et al. Effect of 1-(1-naphthylmethyl)-piperazine, a novel putative efflux pump inhibitor, on antimicrobial drug susceptibility in clinical isolates of *Escherichia coli*. *J Antimicrob Chemother* 2006; **57**: 339–43.
- 9 Buffet-Bataillon S, Branger B, Cormier M et al. Effect of higher MICs of quaternary ammonium compounds, in clinical *E. coli* isolates, on antibiotic susceptibilities and clinical outcomes. *J Hosp Infect* 2011; **79**: 141–6.
- 10 Garcia-Migura L, Sunde M, Karlsmose S et al. Establishing streptomycin epidemiological cut-off values for *Salmonella* and *Escherichia coli*. *Microb Drug Resist* 2012; **18**: 88–93.
- 11 Sunde M, Norstrom M. The genetic background for streptomycin resistance in *Escherichia coli* influences the distribution of MICs. *J Antimicrob Chemother* 2005; **56**: 87–90.
- 12 Jove T, Da Re S, Denis F et al. Inverse correlation between promoter strength and excision activity in class 1 integrons. *PLoS Genet* 2010; **6**: e1000793.
- 13 Livak KJ, Schmittgen TD. Analysis of relative gene expression data using real-time quantitative PCR and the 2^{- $\Delta\Delta$ CT} method. *Methods* 2001; **25**: 402–8.
- 14 Beenken KE, Dunman PM, McAleese F et al. Global gene expression in *Staphylococcus aureus* biofilms. *J Bacteriol* 2004; **186**: 4665–84.
- 15 Aono R, Tsukagoshi N, Yamamoto M. Involvement of outer membrane protein TolC, a possible member of the *mar-sox* regulon, in maintenance and improvement of organic solvent tolerance of *Escherichia coli* K-12. *J Bacteriol* 1998; **180**: 938–44.
- 16 Randall LP, Woodward MJ. The multiple antibiotic resistance (*mar*) locus and its significance. *Res Vet Sci* 2002; **72**: 87–93.
- 17 Pages JM, Lavigne JP, Leflon-Guibout V et al. Efflux pump, the masked side of β -lactam resistance in *Klebsiella pneumoniae* clinical isolates. *PLoS One* 2009; **4**: e4817.
- 18 Paulsen IT, Littlejohn TG, Radstrom P et al. The 3' conserved segment of integrons contains a gene associated with multidrug resistance to antiseptics and disinfectants. *Antimicrob Agents Chemother* 1993; **37**: 761–8.
- 19 Nordmann P, Poirel L. Emergence of plasmid-mediated resistance to quinolones in Enterobacteriaceae. *J Antimicrob Chemother* 2005; **56**: 463–9.
- 20 Wang A, Yang Y, Lu Q et al. Presence of *qnr* gene in *Escherichia coli* and *Klebsiella pneumoniae* resistant to ciprofloxacin isolated from pediatric patients in China. *BMC Infect Dis* 2008; **8**: 68.
- 21 Zgurskaya HI, Krishnamoorthy G, Ntrel A et al. Mechanism and function of the outer membrane channel TolC in multidrug resistance and physiology of enterobacteria. *Front Microbiol* 2011; **2**: 189.
- 22 Karczmarczyk M, Martins M, Quinn T et al. Mechanisms of fluoroquinolone resistance in *Escherichia coli* isolates from food-producing animals. *Appl Environ Microbiol* 2011; **77**: 7113–20.
- 23 O'Regan E, Quinn T, Pagès JM et al. Multiple regulatory pathways associated with high-level ciprofloxacin and multidrug resistance in *Salmonella enterica* serovar Enteritidis: involvement of RamA and other global regulators. *Antimicrob Agents Chemother* 2009; **53**: 1080–7.